



BDW16DW Ultra high-pressure

COMPACT BRAZED HEAT EXCHANGER

Thermal efficiency and Double Wall safety: the BDW-type

This double-wall product is designed for applications where a leak can be crucial and must therefore be detectable. The design offers the same compactness and thermal performance as other SWEP CBEs.

Ultra-high pressure units are an excellent choice when the design pressure of the system is very high. This includes applications such as carbon dioxide heat pumps and supermarket refrigeration. The units are standard-pressure units reinforced with a steel frame held together by bolts.

Easy to choose the right product solution

With SWEP's unique SSP CBE, the SWEP Software Package, you can do advanced heat transfer calculations yourself, and choose the product solution that suits your application best. It's also easy to choose connections and generate drawings of the complete product. If you would like advice, or you would like to discuss different product solutions, SWEP offers all the service and support your need.

THIRD-PARTY APPROVALS (selection)

Europe, Pressure Equipment Directive (PED 97/23/EC)

For additional information please contact your local SWEP representative. SWEP reserves the right to make changes without prior notice.

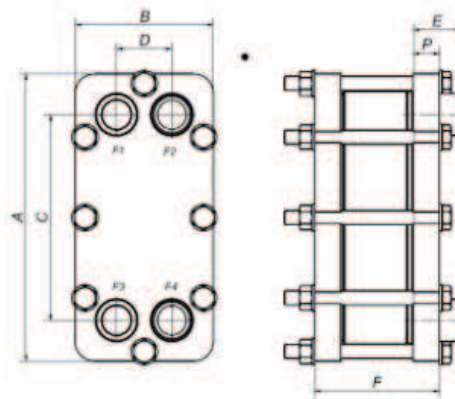

Measurements(mm)		Tolerance
A	417	+2 /-2
B	159.5	+1 /-1
C	329	+1 /-1
D	72	+1 /-1
E	20.1	+1 /-1
F	84+2xNP	+0.5% /-1.5%
G	0	+1 /-1

Port size F/P: 27mm

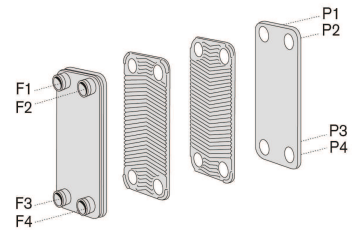

CBE port denomination

STANDARD CONNECTIONS

For specific dimensions, or information about other types of connections, please contact your SWEP sales representative.

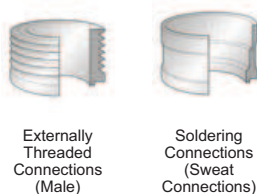

TECHNICAL DATA

Max working pressure at 150°C

Test pressure:
Min temperature:
Max temperature:
Max number of plates (NoP)
CBE weight

Hold-up volume: inner circuit

Plate material:

Brazing material:
Standard connection material

Inner circuit: 140 bar (2031psi)
Outer circuit: 140 bar (2031psi)
210 bar (3046psi)
-10°C (14F)
150°C (302F)
100
48.47+NoPx0.22kg
(106.9+NoPx0.5lbs)
(NoP/2-1)x0.061 litres
(NoP/2-1)x0.002 gal.)
Parts in contact with fluid:
AISI 316
Parts not in contact with fluid:
AISI 304
Pure Copper
AISI 316

CAPACITY GRAPH

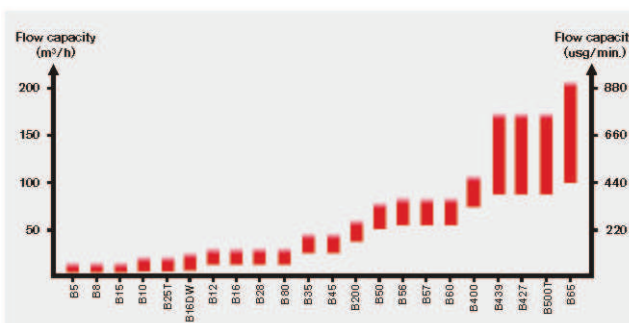

MATERIAL DISCLAIMER

The information and recommendations in regards to the products are presented in good faith, however, SWEP makes no representations or warranties as to the completeness or accuracy of the information. Information is supplied upon the condition that the purchasers will make their own determination as to the products' suitability for their purposes prior to use. Purchasers should note that the properties of the products are both application and material selection dependent and that products containing stainless steel, both 316 and 304 families, are still subject to corrosion if used in unsuitable environments. Purchasers should also be advised that stainless steel from the 304 family can be more sensitive in regards to corrosion than stainless steel from the 316 family. By purchasing products displayed here upon SWEP disclaims all responsibility due to corrosion of the products and/or other materials attached to the products and also for any damages resulting from the use of the products.



A DOVER COMPANY

SWEP INTERNATIONAL AB

Box 105, SE-261 22 Landskrona, Sweden
Phone +46 418 40 04 00
Fax +46 418 292 95
Internet: www.swep.net
E-mail: info@swep.net